

FLUID CONTROL DIVISION

Parker Hannifin Corporation
95 Edgewood Avenue
New Britain, CT 06051
Telephone (860) 827-2300

IOM-LS
(Rev 1121)



INSTALLATION, OPERATING & MAINTENANCE INSTRUCTIONS PA SERIES ANGLE SEAT VALVES WITH LIMIT SWITCH 2-WAY NORMALLY CLOSED 2-WAY NORMALLY CLOSED ANTI-WATER HAMMER



WARNING

GENERAL SAFETY INSTRUCTIONS BEFORE INSTALLATION

FAILURE OR IMPROPER SELECTION OR IMPROPER USE OF THE PRODUCTS AND/OR SYSTEMS DESCRIBED HEREIN OR RELATED ITEMS CAN CAUSE DEATH, PERSONAL INJURY AND PROPERTY DAMAGE.

This document and other information from Parker Hannifin Corporation, its subsidiaries and authorized distributors provide product and/or system options for further investigation by users having technical expertise. It is important that you analyze all aspects of your application, including consequences of any failure, and review the information concerning the product or system in the current product catalog. Due to the variety of operating conditions and applications for these products or systems, the user, through its own analysis and testing, is solely responsible for making the final selection of the products and systems and assuring that all performance, safety and warning requirements of the application are met.

The products described herein, including without limitation, product features, specifications, designs, availability and pricing, are subject to change by Parker Hannifin Corporation and its subsidiaries at any time without notice.

Carefully read installation, operation and maintenance procedures prior to installing or servicing valve.

Do not use valve as a safety shut-off valve when making repairs.

Do not install a valve before depressurizing system down to atmospheric pressure.

Care must be taken to ensure that the valve materials selected are suitable for the media being handled. Parker assumes no liability for damage caused by improper material selection in the case of corrosion from aggressive media.

CAUTION: *Do not, at any time, make any alteration or modifications to any angle seat valves without the express and written approval of Parker's Fluid Control Division.*

DESCRIPTION

These valves are 2-way normally closed (N.C.) valves in stainless steel construction. The valves can be actuated pneumatically. The pilot operated models require a minimum operating pressure differential to ensure valve operation.

Pilot valves may be ordered separately.

PRINCIPLES OF OPERATION

2-way PA Series - NORMALLY CLOSED VALVES

The angle seat valve is kept closed by a spring which presses against a piston and piston rod forcing the seating seal tightly against the valve seat. When pressure is applied to the actuator pilot connection, the piston, piston rod and thus the seating seal are raised opening the valve.

The valve tightly closes when pressure is removed from the pilot connection.

The maximum permitted angle seat valve pressure and pilot valve pressure and temperature ranges are described on the valve nameplate.

CAUTION: *A minimum pilot operating pressure is required for proper angle seat valve operation.*

Installation Instructions

Mounting position and pressure limits: Valves can be mounted directly on piping and are designed to operate in any position. The valves may be installed in any line regardless of the direction in which the line runs. However, for optimum life and performance the valves should be mounted vertically upright so as to minimize wear and reduce the possibility of foreign matter accumulating inside the stem area.

Line pressure and pilot pressure must conform to Actuator nameplate rating.

WARNING: *Depressurize system and turn off electrical power to the pilot valve before attempting to remove valve from piping. Failure to depressurize the system could result in injury.*

CAUTION: *When the valve is to be removed from the piping system, the pipeline must be drained completely before removing the valve, especially with hazardous or aggressive media that can be hazardous to health.*

Installation Steps

Installation must be done according to all applicable Safety Codes and Standards and by qualified personnel.

Inspect valve prior to installation. Damaged valves or actuators must not be installed.

Ensure that the valves are installed whose pressure class, line pressure, type of connection and connection dimensions correspond to the usage conditions.

WARNING: *Do not install a valve whose permitted pressure / temperature ratings are inadequate to meet the operating conditions.*

Piping: Remove any protective enclosures from the body ports and connect line pressure to the inlet port of the valve. An arrow on the body indicates direction of flow. Use of Teflon tape, thread compound or sealant is permissible, but should be used sparingly on male pipe threads only. Connect outlet line to the opposite port.

Ports should not be subjected to excessive torque by use of an oversized wrench, wrench extension or by impacting the wrench handle. Do not use the valve to “stretch” or “align” the pipe. Using the pipe to close a large gap can distort the valve or at least stress it unduly, and possibly cause it to malfunction, or the threaded ports may be damaged or stripped.

Actuation Connection

Actuator position can be adjusted with a clockwise rotation of the actuator.

Connecting the actuator to the control:

A 3-way pilot is required to connect the control pressure for actuator functionality.

For actuator types with springs, connect the pilot pressure to the inlet of the pilot valve and the outlet of the pilot valve to the threaded connection on the actuator head.

Pressure Testing and Valve Functioning

It is recommended that newly installed pipeline systems first be flushed thoroughly to wash out all foreign matter.

The test pressure of an open valve must not exceed 1.5 times the maximum rated pressure of the angle seat valve. The test pressure of a closed valve must not exceed 1.1 times the maximum rated pressure of the angle seat valve.

Normal Operation and Maintenance

The angle seat valves are operated by pneumatic control signals. The valves do not require regular maintenance work.

During routine system checks, no leakage should be found in the valve. If unacceptable leakage occurs, reference “Troubleshooting” section for recommended solutions.

CAUTION: *When the valve is to be removed from the piping system, the pipeline must be drained completely before removing the valve, especially with hazardous or aggressive media that can be hazardous to health.*

NOTE: *Depending on service conditions, fluid being used, filtration, and lubrication, it may be required to periodically clean or replace the valve.*

For liquids, use versions with flow direction under the seat to avoid water hammer effect

CAUTION: *Do not expose plastic or elastomeric materials to any type of commercial cleaning fluid. Parts should be cleaned with a mild soap and water solution.*

Reference Cross Section drawings on the following page.

APPROVAL

Parker Hannifin Fluid Control Division certifies its valve appliance products complies with the essential requirements of the applicable European Directives.

We hereby confirm that the appliance has been manufactured in compliance with the applicable standards and is intended for installation in a machine or application where commissioning is prohibited until evidence has been provided that the machine or application is also in compliance with EC directives.

The angle seat valve family complies with European Pressure Equipment Directive 2014/68/EU in accordance with Annex II, Category II, Group 2, Module A1.

WARNING: THIS PRODUCT HAS NO AGENCY APPROVAL FOR USE IN HAZARDOUS LOCATIONS.

Technical Specifications

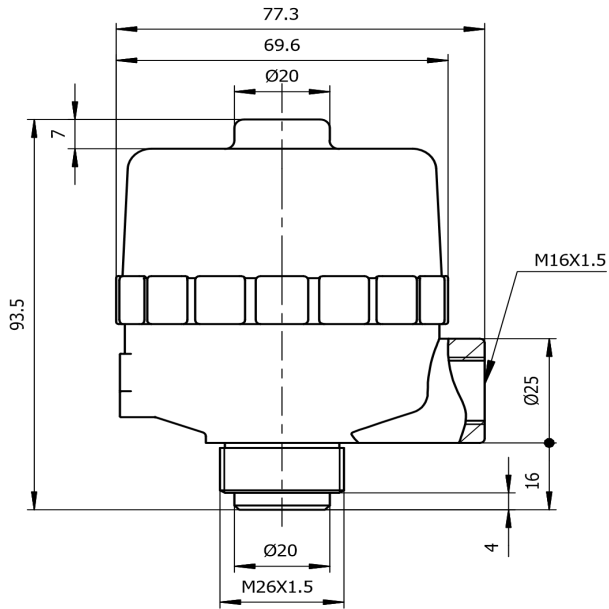

Figure 1. Limit Switch dimensions

| Technical Data | Description |
|---------------------|---|
| LED | Yellow: Voltage Indicator Red: Valve Closed Green: Valve Open |
| Ambient Temperature | -4 to 140°F (-20 to +60°C) |
| Nominal Voltage | DC12V-0.11W DC24V-0.45W DC48V-1.8W |

Table 1. Technical Specifications

Electrical Connections

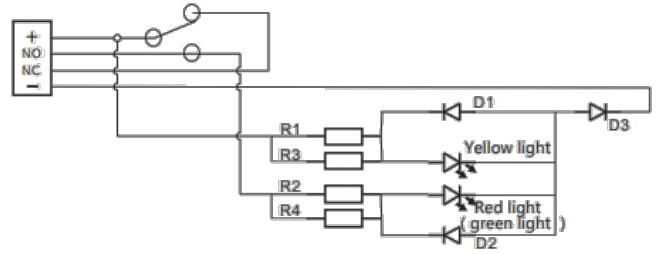

Figure 2. Limit Switch wiring schematics

Operation

The limit switch box is supplied with two mechanical switches with LEDs. It mounts on top of the valve actuator housing in place of the standard visual indicator.

As the valve strokes, cams on the limit switch box internal stem operate the switches to provide a visual indication and electrical signal of the valve position.

The limit switch box can rotate 360°.

This function is available on normally closed valves with actuators ranging from 40 to 100 mm.

Nomenclature

The suffix -LS is added to a standard Normally Closed valve: PA15SAN4S050A-LS

| Type | Add Suffix |
|----------------|------------|
| Two Mechanical | -LS |

Table 2. Limit Switch Nomenclature

Reference Cross Section Drawings and Product Picture

Diagram of Normally Closed Valve and Product Picture

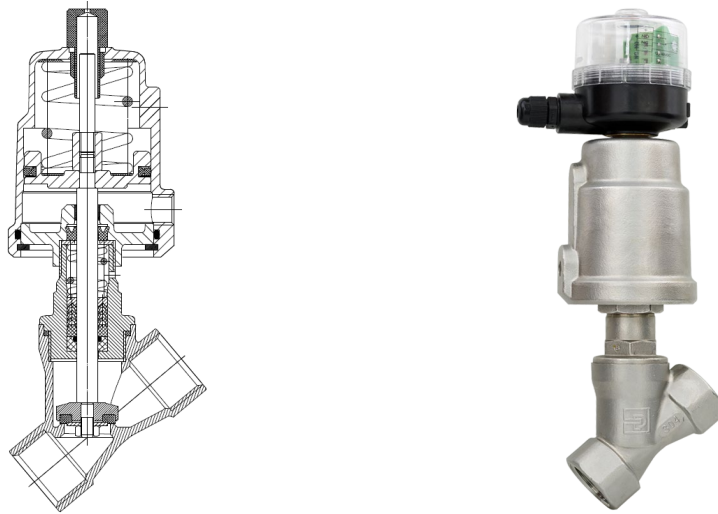

| TROUBLESHOOTING | |
|--|---|
| PROBLEM | PROCEDURE |
| Angle Seat Valve (NC, NO) fails to operate. | <ol style="list-style-type: none"> 1. Check that pilot air supply is properly connected. 2. Verify that pilot air supply meets the minimum pressure required to actuate the specific angle seat valve model number. |
| Angle Seat Valve fails to close (normally closed valve). | <ol style="list-style-type: none"> 1. Check that the Angle Seat Valve opens and closes properly when pilot air is applied and removed from the valve actuator. 2. Verify that there is no obstruction in the valve. 3. Verify that pilot valve is vented from valve actuator. |
| Angle Seat Valve fails to open (normally open valve). | <ol style="list-style-type: none"> 1. Check that the Angle Seat Valve opens and closes properly when pilot air is applied and removed from the valve actuator. 2. Verify that there is no obstruction in the valve. 3. Verify that pilot valve is vented from valve actuator. |
| Internal Seating Seal Leakage. | <ol style="list-style-type: none"> 1. Check if the actuator has closed the valve 100 percent. 2. Verify that there is no obstruction in the valve that can prevent full closure. 3. Examine orifice in body for nicks. Damage may require a new replacement valve. 4. Inspect the seat sealing material for foreign matter or dirt accumulation. Worn sealing material requires valve replacement. |
| Yellow Lights Not Illuminated. | <ol style="list-style-type: none"> 1. Verify 12 – 48 VDC power supply is delivered to the correct terminals and with the correct polarity. |
| Green Light Not Illuminated. | <ol style="list-style-type: none"> 1. Verify 12 – 48 VDC power supply is delivered to the correct terminals and with correct polarity. 2. Check that pilot air supply is properly connected. 3. Verify that pilot air supply meets the minimum pressure required to actuate the specific angle seat valve model number. 4. Verify that stem/switch contacts are properly adjusted. |
| Red Light Not Illuminated. | <ol style="list-style-type: none"> 1. Verify 12 – 48 VDC power supply is delivered to the correct terminals and with the correct polarity. 2. Verify that pilot valve is vented from valve actuator. 3. Check that the Angle Seat Valve opens and closes properly when pilot air is applied and removed from the valve actuator. 4. Verify that there is no obstruction in the valve. 5. Verify that stem/switch contacts are properly adjusted. |